

**Beaver Dam Raceway Park**  
**RULE BOOK AMENDMENT**  
**SECTION 2**  
**TRACK PROCEDURES - 2010**

**1.8 Safety**

Paragraph 2 is amended to read as follows: All ATV's and other power driven equipment used in the pit area must be registered with the Raceway and have proof of insurance. Bicycles, mopeds, and motorcycles are prohibited in the pit area. ATV's are to be used for pushing midgets only. ATV's are not allowed to be used in any other manner. All ATV'S must maintain proper pit speed and use or will be parked for a period of time to be determined by the track staff.

**2.1.8 Race Lineup**

Paragraph 3 is added to read as follows:

Midget cars showing up late to the lineup area will not be pushed off if all the available cars in the lineup area have completed push off. Midget cars requiring a second push off must start or restart the race at the rear of the field. Alternates are not used in the Midget Car Division at Beaver Dam Raceway. Midget race lineup will be determined by Beaver Dam Raceway staff. The heat and feature line-up procedure will be posted and available at the raceway office .

**2.1.9 Race Length**

Paragraph 5 is added to read as follows:

Midget cars reentering the race track from the work area must reenter the track off turn 3, if approved by Beaver Dam Raceway Officials.

**2.1.10 Car Repair**

Paragraph 3 is added to read as follows:

Midget car repair will be performed in the designated work area off turn 3. Midgets utilizing the work area in a heat race must be ready to push off when the "going green next time by" signal is given. Any cars not ready to push off at that time will not be restarted. Midgets will be put on a two (2) minute clock from the time the car enters the work area for the A- main only. Any midget car not ready to push off at the conclusion of the two minute time period will not be restarted. Any midget car entering the pit area will not be restarted.

2.1.12.1 Add to paragraph three : Midget restarts will be single file nose to tail. All other track restart procedures apply.

**2.1.12.4 Yellow flag**

Paragraph 1 is amended to read as follows:

The yellow flag, and/or yellow light, indicates caution on the track. All cars receiving this flag, and/or light, must slow, hold their position, and form a single line behind the lead car. **Absolutely no racing back to the yellow flag.** The penalty for racing back to the yellow flag, as determined by the flagman, is restarting the race at the rear. If a pace vehicle is used, the leader must line up behind it. Cars will be lined up as they were scored on the last completed lap. Lapped cars must maintain their track

position. Any cars entering the pits during the caution period must restart the race at the rear, in the order they return to the track. Reentry under the yellow flag is not permitted until the lineup is complete. **Midget cars may only reenter the track off turn 3 from the designated work area. Any midget car entering the pit area will not be allowed to reenter the track.**

#### **2.1.12.5 Red Flag**

**Paragraph 1 is amended to read as follows:**

The red flag, and/or red light, indicates that the race must stop immediately, regardless of the position of the cars on the track. **All red flags are closed reds. During a red flag, pit crew members are not allowed on the track.** Drivers may exit their car for inspection purposes only. All car repairs must be done in the pits. **Midget car repairs must be performed in the designated work area off turn 3. Midget cars may not be worked on during the red flag. The two minute time clock for midget cars under repair will start when the track condition changes to yellow.** Any cars entering the pits during a red flag must restart the race at the rear, in the order they return to the track.

2.1.12.9 Midget Pit Procedure Midget hauler parking is on the south end of the main pit area. All midgets must shut their engines off as soon as they enter the pit area when exiting the racetrack. They must be pushed through the pit area. Any driver not following this procedure will be penalized per the penalty section of the rulebook.

#### **2.1.17 Track Radio Frequency**

**Paragraph 2 is added to read as follows:**

**All drivers in competition are required to have a working Raceciever tuned to the designated channel number 1561)469.500) .Midget drivers will use their designated channel. All cars in competition are required to have a working Westhold transponder (silver side facing the track). Failure to comply with Raceciever or transponder requirements will result in a penalty. Penalties will be imposed in accordance with **SECTION 4 - PENALTIES.****

#### **2.2.1 Payout Procedures**

**Paragraph 6 is added to read as follows:**

**Midget car drivers will be paid by BMARA in accordance with their payout schedule.**

## **Beaver Dam Raceway Park**

### **RULE BOOK AMENDMENT SECTION 5 MODIFIED DIVISION - 2010**

#### **5.14 TIRES/WHEELS**

Paragraph 1 is amended to read as follows:

Must use unaltered Hoosier G60-15 tire with or without I.M.C.A. stamped on the sidewall. No softening, or grooving of tires. Tire grinding or siping permitted on the tread face only of the tire. May not extend past factory edge line of tire. Tire reconditioning subject to approval of technical inspector. No re-caps. All wheels must be steel, 15-inches diameter, 8-inches wide, minimum shell thickness 0.095-inches, and minimum 19.0 pounds. No wide-five wheel adapters allowed. Aluminum or steel spacers only. May use external, steel bead lock on right rear only and it cannot make wheel any narrower than 8-inches and no wider than 8.75-inches. Must use only steel bolts. Foam type or soft plastic **disc** mud plug allowed on right side tires only. **Plastic disc mud plugs must have car number.** ~~Compression style mud plugs are prohibited.~~ May use an inner mud plug on the left rear only. Rim-mounted bleeder valves allowed. A MINIMUM TIRE PRESSURE OF 12 LBS WILL BE ENFORCED ON THE RIGHT REAR.

**Beaver Dam Raceway Park**  
**RULE BOOK AMENDMENT**  
**SECTION 6**  
**GRAND NATIONAL DIVISION - 2010**

**6.12 WHEELS AND TIRES**

Paragraph 1 is amended to read as follows:

Racing steel wheels of 8" maximum width. Bead locks are allowed on all wheels. Foam type or soft-plastic ~~disc~~ mud plug allowed **on right side only**. ~~Plastic disc mud plugs must have car number.~~  
~~Compression ring style mud plugs are prohibited.~~

**Beaver Dam Raceway Park**  
**RULE BOOK AMENDMENT**  
**SECTION 7**  
**STREET STOCK DIVISION - 2010**

**7.7.3.1 Wheels**

Paragraph 2 is amended to read as follows:

Wheel spacers are prohibited. Pressure bleeders are illegal. Bead lock permitted on right rear only. One foam type or soft plastic **disc** mud plug allowed on right rear only. **Plastic disc mud plugs must have car number.** ~~Compression ring style mud plugs are prohibited.~~

**Beaver Dam Raceway Park**  
**RULE BOOK AMENDMENT**  
**SECTION 8**  
**SPORTMOD DIVISION - 2010**

**8.5 BODY**

Sportmod body diagram is amended to read as follows:

**SportMod Body Dimensions**

A	20" max. 16" min. (ground to center of bumpers, front and rear)	Q	38" max. 28" min.
B	--- 6.5" min (center to center)	R	Max. no wider or lower than <b>2-inches outside of</b> front frame horns. Min. 24" nose must be flat and flush with sides.
C	52" max. 42" min.	S	66" max. 24" min. must cover radiator.
D	4" max. Hood drop (sides), sealed off from driver's compartment and max. 3" rake.	T	52" max. 44" min.
E	42" max.	U	56" max. 41" min. (fiberglass only)
F	6" max.	V	All tires must be outside body and nerf bar and visible from front, rear, and top. <del>Minimum</del>
G	4" min. Door may extend maximum 6" past block at bottom on both sides.		<del>6" tire outside of body.</del>
H	19" max., must be same on both sides	W	66" max. 53" min. Same front to back.
I	112" max. 108" min.	X	43" max. 24" min.
J	29" max. 22" min.	<b>Z</b>	<b>3" Minimum</b>
K	72" max. or not past back of block, right side. side may extend forward to cover foot box.		REAR FILLER PANEL: 8" min. / 90 degree angle. Must be solid, attached to deck, extended to quarter panels, attached to deck.
L	18" max. 12" min. opening, both sides.		SPOILER BRACES: Maximum 3 total. Bottom edge of spoiler brace must be flush with rear edge of interior deck.
M	With level, must have no more than 2" clearance at rear of roof, and 5" at top front.		SAIL PANELS: Must be within confines of these dimensions and same on both sides. Must mount within 2" of outside edge of interior deck.
N	120" max. 106" min.		
O	48" max. 34" min.		
P	Interior slope is 6" max. front to rear and flat across. If flat at front half of interior you have used up 50% of your 6" so from behind driver to rear you may only have 3". Top of interior must be flush with top of door and quarter panels. Optional escape hatch from driver to passenger door allowed.		

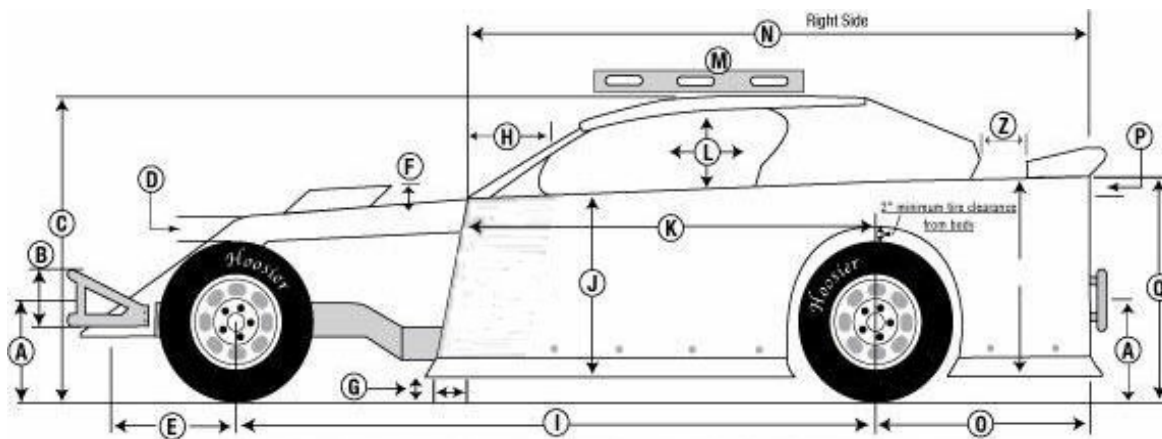

All body measurements are max. unless otherwise specified. Dimensions have zero tolerance.

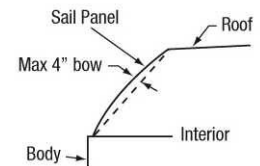
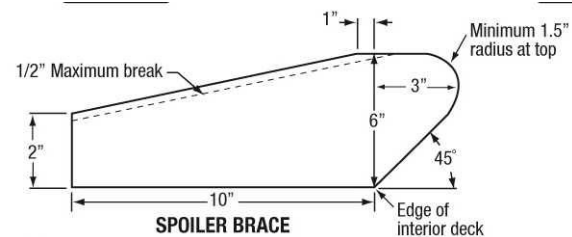
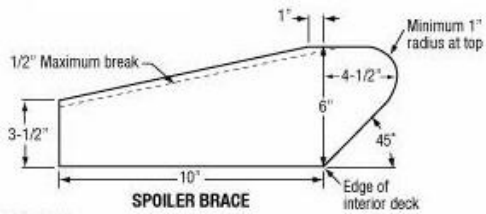
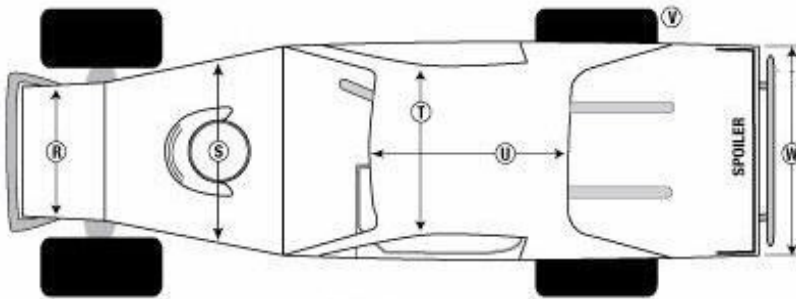

## 8.14 TIRES/WHEELS

Paragraph 1 is amended to read as follows:

Must use unaltered Hoosier G-60-15 IMCA plated tire, or American Racer G-60 (KK704) Plated or unplated tire. In 2011 the American Racer tire will not be permitted. No softening or grooving permitted. Tire grinding or siping permitted on the tread face only of the tire. May not extend past factory edge line of tire. No recaps permitted. Wheels must be 3-inch or 4-inch backspace only. No wheel adapter, spacers or bleeder valves permitted. Steel bead lock with steel bolts, on outside, on right rear only. Inner mud plug may be used on left rear. Soft plastic disc or foam mud plug on right rear only. **Plastic disc mud plugs must have car number.** Wheel width: minimum 8-inches; maximum 8.750-inches. All wheels must be 15-inches diameter with a minimum shell thickness of 0.095-inch

minimum and a minimum weight of 19 lbs. One-inch lug nuts required. A MINIMUM TIRE PRESSURE OF 12 LBS WILL BE ENFORCED ON THE RIGHT REAR.

## **Beaver Dam Raceway Park**

### **RULE BOOK AMENDMENT SECTION 9 LEGEND CARS DIVISION - 2010**

#### **9.3.75 Wheels**

Paragraph 1 is amended to read as follows:

Any type of automotive steel wheel (no bead lock) that has a 13" diameter, a 7" width and the offset of only 3 1/8" with an 1/8" variance (3" to 3 1/4") is permitted. Starting March 1, 2011, only Unique Wheels (part #246-3744 / Black & #34-3744 / Chrome) & Bassett Wheels (part #37ST3S / Silver & #37ST3 / Black) as delivered by 600 Racing, Inc. will be permitted for use on Legend Cars at any INEX sanctioned event. INEX approved bead lock wheel, with ~~soft~~ **foam or plastic disc** mud plug, permitted on right rear only. **Plastic disc mud plugs must have car number.** The minimum weight of a tire and wheel must be at least 36.0 pounds without additional steel, lead, or wheel weights. All wheel weights must be covered with duct tape. Bleeder or relief valves are not permitted in the wheels.

## **Beaver Dam Raceway Park**

### **RULE BOOK AMENDMENT**

#### **SECTION 10**

#### **BMARA MIDGET CAR DIVISION - 2010**

**SECTION 10 is added to read as follows:**

All midget cars must be constructed in accordance with 2010 BMARA rules. All midget cars must be inspected prior to competition. Any car that has not been inspected, or does not have a current year Beaver Dam inspection sticker, will not be allowed on the track.

Safety restraint systems, seat belts, must be date stamped 2008, 2009, or 2010.

Mufflers are required at all times while car is on track and in competition. Noise level must meet track decibel limits. 95-decible limit 100 feet from car. Loss of muffler or exceeding track decibel limits is an immediate disqualification. If a muffler is missing from the car in post race tech it is a disqualification.

A working Raceciever model SW1600, tuned to channel 1561(469.500) is mandatory. A working Westhold transponder (silver side facing the track) is required. Transponder to be mounted in the rear of the car, typically, to the bottom of the torsion tube area. Drivers of cars without torsion tubes should contact a Beaver Dam Technical Official for proper location.

All ATV's and other power driven vehicles used in the pit area must be registered with Beaver Dam and have proof of insurance. Use of ATV's restricted to pushing cars only. Any team in violation of this policy will forfeit use of ATV's for remainder of the season.